

S4MK



FEATURES

- BODY:** – Made of zinc alloy.
- SHACKLE:** – Made of hardened steel.
– Diameter: 4.7 mm.
- OPENING / LOCKING:** – Using the wheels or key override.
- WHEELS:** – 4 wheels with 10 digits each.
– 10.000 possible differs to choose.
- KEYS:** – Standard key.
– The product is supplied without keys, unless it is asked at the point of sale or is requested directly to IFAM.
- PACKAGING:** – Box packed.

SERVICES

- Laser engraving service

DIMENSIONS

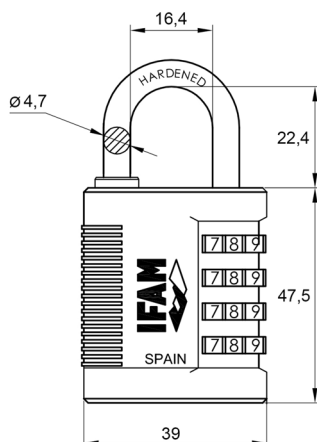

Ref.	Cod.	IPL	Pack	Uni.
S4MK KN	000688	8		7